

CLEARANCE OFFERS

LA9587-CLEAR

Axolight Spillray Pendant CLEARANCE

SOURCE: <https://www.davidvillagelighting.co.uk/product/Axolight-Spillray-Pendant-CLEARANCE/10619>



PRODUCT DESCRIPTION

Designer: Manuel Vivian

Axolight Spillray Suspension

**BRAND NEW, DISCONTINUED. BOXED IN B-GRADE ORIGINAL PACKAGING.
1 x Crystal Available.**

The stunning single Spillray suspension light was designed by Manuel Vivian, who specialises in blown glass to make beautiful and graceful creations. This suspension is both artisanal and refined, a simple glass shade that subtly reveals the light source to create a refined and gentle glow.

The Spillray pendant is available in 3 different sizes that have their own unique shape, being a mixture of square and rectangular silhouettes. You can also choose between 3 finishes, giving you variety and versatility to find the perfect match for your space. This pendant light works best as an atmospheric light that can be used to create a cosy corner or to illuminate the room.

PRODUCT SPECIFICATION

Light Source: 1 x Max 1.5W 12V_{DC} LED G4 (Excluded)

IP Code: 20

Dimming: Non-Dimmable

Dimensions: Shade: Ø10cm
Glass Height: 14cm
Pendant Height: 29.3cm

Ceiling Canopy: Ø13.2cm x 4.3cm
Max. Drop Height: 200cm

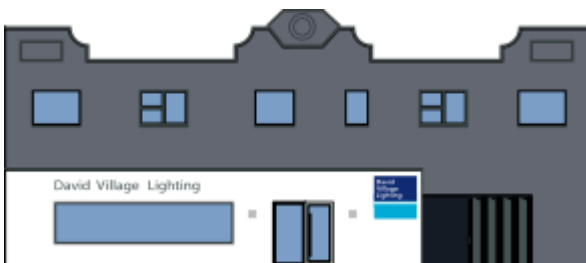
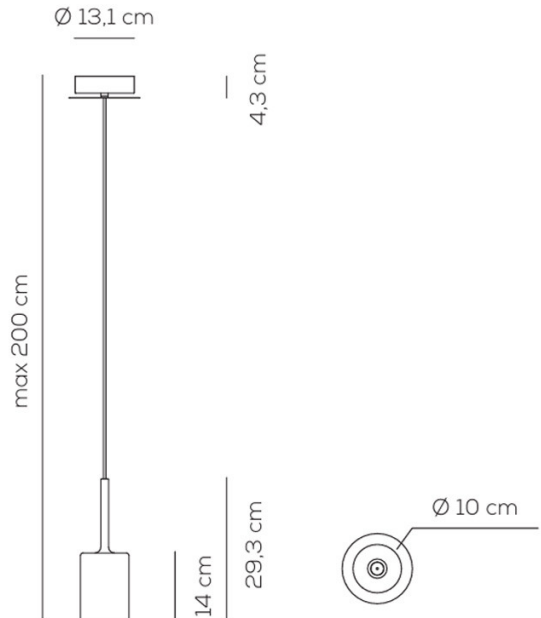

For all sales and technical enquiries, please contact:

+44 (0)114 263 4266

info@davidvillagelighting.co.uk

www.davidvillagelighting.co.uk