

Artemide

Artemide Ripple Cluster 3 LED Suspension

LA10400/C

SOURCE: <https://www.davidvillagelighting.co.uk/product/Artemide-Ripple-Cluster-3-LED-Suspension/21638>

PRODUCT DESCRIPTION

Designer: BIG

Artemide Ripple Cluster 3 LED Suspension

The Ripple Cluster 3 Suspension shapes the quality of the space around it, combining efficient lighting with sound absorption. The suspension is comprised of three circular structures made from heat-conducting moulded plastic, which allows for high-power LEDs to be used for bright and effective lighting. If required, this functional lighting can be enriched with the addition of a sound-absorbing diffuser, well-suited for office spaces and busy restaurants.

Produced by Artemide with BIG, the Ripple Cluster 3 merges technical innovation with a minimalistic composition for a simplistic-looking design that offers unlimited potential. While a single suspension creates a striking presence above a table or work surface, the Ripple has been designed to be displayed in large formations, offering freedom of configuration. Display in clusters with different-sized suspensions from the [Ripple Collection](#) for a scalable lighting solution that perfectly fits the space around it.

The Ripple Cluster 3 is also available to purchase with an acoustic fabric diffuser for a warmer glow. Please [contact us](#) for prices and more info.

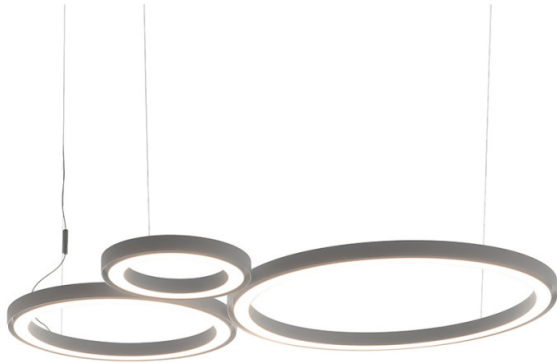

PRODUCT SPECIFICATION

- Light Source:** 89W, 3000K, 5806 Lumens
- IP Code:** 20
- Dimming:** Dimmable via Dali/1-10v/push to make/ switch dimming systems. Please consult your electrician; additional wiring may be required on-site.
- Dimensions:** Width: 135cm
Length: 153cm
Maximum Drop: 165cm

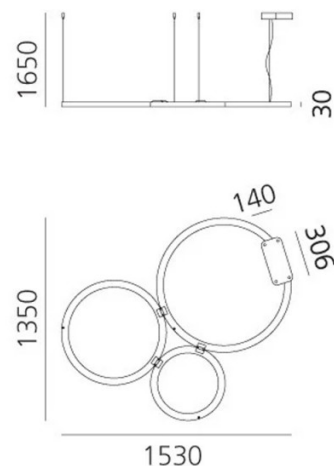



For all sales and technical enquiries, please contact:

+44 (0)114 263 4266

info@davidvillagelighting.co.uk

www.davidvillagelighting.co.uk